

Design and Simulation of a Digital Voltmeter

Jinqiu Zhang
School of Electronic Information and Electrical Engineering
Yangtze University
Jingzhou, China

Abstract: Voltage measurement is a common procedure in electronic science experiments. With technological advancements, higher requirements have been placed on the accuracy and reliability of voltmeters, giving rise to the demand for the development and design of digital voltmeters. Considering the comprehensive cost and detection performance, this paper presents a multi-channel digital voltmeter simulation system based on the Proteus platform, with a 51-series microcontroller as the core and the ADC0808 analog-to-digital converter. The system can collect analog voltage signals in the range of 0–5 V in real time, convert them into digital quantities through 8-bit A/D conversion, and finally display each channel voltage value cyclically on six 7-segment digital tubes. Through Proteus simulation tests, the system achieves synchronous acquisition and stable display of 8-channel voltage signals, and all performance indicators meet the design requirements. This design provides a theoretical basis and technical verification for the development of practical digital voltmeters, and has high teaching reference value and application potential.

Keywords: Digital Voltmeter; 51-series Microcontroller; A/D Conversion

1. INTRODUCTION

Voltage measurement is a fundamental and essential operation in electronic experiments, industrial production monitoring and equipment debugging. Traditional analog voltmeters have limitations such as human reading errors and inability to realize multi-channel synchronous measurement, which are difficult to meet the high-precision and multi-scenario measurement needs of modern electronic technology. Digital voltmeters with digital display, high precision and programmable control characteristics have gradually become the mainstream of voltage measurement equipment, and their research and development are closely combined with microcontroller and analog-to-digital conversion (A/D) technology[1].

Current commercial digital voltmeters have obvious shortcomings in university teaching experiments and small-scale industrial on-site detection: high-end precision models are expensive and not suitable for large-scale teaching use; low-cost models have single functions, only support single-channel measurement, and lack flexible data display and protection mechanisms. In addition, most designs focus on hardware performance improvement, with low software and hardware integration, which is not conducive to students' hands-on practice and understanding of the design principle of digital voltmeters.

Aiming at the above problems, this paper designs a multi-channel digital voltmeter simulation system based on the Proteus platform, with 51 single-chip microcomputer as the core and ADC0809 as the A/D conversion chip. The system realizes real-time acquisition of 0~5V analog voltage signals and cyclic display of 8-channel voltage data through the LCD12864 module, with the measurement error controlled within 0.02V. The whole system adopts modular design with simple structure, clear logic and low development cost[2].

This design not only provides a highly operable low-cost scheme for university electronic experiment teaching, helping students master the core technologies such as single-chip microcomputer control and A/D conversion, but also has good expandability[3]. It can be further optimized with functions such as multi-range switching and data storage for small-scale industrial on-site voltage monitoring, and provides a reference for the rapid design and verification of similar electronic measurement equipment based on simulation platforms.

2. SYSTEM DESIGN SCHEME

This part focuses on the overall architecture design, core device selection principles and core design indicators of the multi-channel digital voltmeter system, and clarifies the design framework and functional requirements of the system with the design goals of low cost, high practicability and meeting the measurement precision requirements, laying a foundation for the subsequent hardware and software implementation.

2.1 Overall System Architecture

Based on the Proteus simulation platform, the designed multi-channel digital voltmeter takes the AT89C51 single-chip microcomputer as the core control unit, and the whole system is modularly designed into four functional modules: analog voltage acquisition module, A/D conversion module, core control module and display module. The modular design not only simplifies the circuit structure and reduces the difficulty of debugging, but also is conducive to the subsequent expansion and optimization of system functions.

The overall working logic of the system is clear and hierarchical: the analog voltage signal in the range of 0~5V is first collected by the voltage acquisition module composed of sliding rheostats, and the signal is adjusted to meet the input requirements of the A/D conversion chip; then the ADC0809 chip in the A/D conversion module converts the collected analog voltage signal into an 8-bit digital signal that can be recognized and processed by the single-chip microcomputer; the core control module with AT89C51 as the core receives the digital signal transmitted by the A/D conversion module, and completes data calculation, format conversion and functional coordination through the pre-programmed program; finally, the processed voltage data is transmitted to the LCD12864 display module, and the 8-channel voltage value is cyclically and stably displayed in a formatted manner, thus realizing the whole process of voltage signal acquisition, conversion, processing and display. Each module is coordinated and controlled by the single-chip microcomputer, and the signal transmission is stable and efficient, which ensures

the real-time and accuracy of the whole voltage measurement process.

2.2 Core Device Selection

The selection of core devices follows the principles of matching system design requirements, low cost, mature technology and easy debugging, and combined with the functional positioning of the system for teaching experiments and small-scale industrial on-site detection, the core chips and modules are carefully selected to ensure the stable operation of the system while controlling the development cost[4]. The detailed selection basis and device characteristics are as follows:

2.2.1 Core Control Chip: AT89C51 Single-chip Microcomputer

AT89C51 is selected as the main control chip of the system, which is a classic 8-bit microcontroller based on the MCS-51 architecture, produced by Atmel Company, and is one of the most widely used single-chip microcomputers in the field of electronic design. The chip is selected for three main reasons: first, it has a perfect development tool ecosystem, which is compatible with Keil C51, the mainstream programming IDE, and can be directly simulated and verified on the Proteus platform, greatly reducing the difficulty of software programming and hardware debugging, which is suitable for the design and teaching application of this system; second, the chip is equipped with 32 general-purpose I/O ports, 4K Flash ROM and 128×8bit RAM, which can fully meet the control requirements of the system for 8-channel data acquisition, A/D conversion timing control and LCD display driving, and has sufficient storage space for storing program codes and temporary measurement data; third, the chip has the advantages of low cost, stable performance and mature application technology, and its parallel bus characteristics can be directly connected with peripheral devices such as ADC0809 without additional logic conversion chips, simplifying the hardware circuit design and reducing the overall development cost of the system.

2.2.2 A/D Conversion Chip: ADC0809

The ADC0809 chip is a CMOS successive approximation type 8-bit A/D converter, which is the core device to realize the conversion of analog voltage signal to digital signal in the system, and its selection is highly matched with the system design requirements. First, the chip has 8 built-in analog input channels (IN0~IN7), which can realize the time-sharing acquisition of 8-channel voltage signals, which is consistent with the multi-channel measurement design goal of the system; second, it adopts 8-bit conversion precision, which can realize the accurate conversion of 0~5V analog voltage signals, and the conversion result can meet the system's design requirement of measurement error within $\pm 0.02V$ after data calculation and processing; third, the chip can be directly matched with the I/O port of AT89C51 single-chip microcomputer for parallel communication, and its start conversion, address latch, conversion end and other control signals can be directly connected with the single-chip microcomputer's general-purpose I/O port, without additional level conversion circuit and complex timing control circuit, which simplifies the hardware connection; in addition, the chip has the advantages of low power consumption, simple working principle and low cost, and its clock signal can be provided by the

single-chip microcomputer's timer, without additional crystal oscillator, further reducing the complexity of the hardware circuit.

2.2.3 Display Module: LCD12864 Dot Matrix Liquid Crystal Display

The LCD12864 dot matrix liquid crystal display is selected as the system's display unit, replacing the traditional nixie tube display, which is more in line with the multi-channel data display requirements of the system. The main advantages of this module are reflected in three aspects: first, it has a 128×64 dot matrix display area, which can realize the synchronous and formatted display of 8-channel voltage data, and can display the channel number, voltage value and unit at the same time, with rich display information and high readability, which is convenient for users to view and record data; second, the module adopts 8-bit parallel communication mode, which only needs to occupy a small number of I/O ports of the single-chip microcomputer for data transmission and control, effectively saving the hardware resources of AT89C51, and the driving program is mature and easy to program; third, the module is equipped with a backlight function, which can be used in different light environments, and its working voltage is 5V, which is consistent with the power supply voltage of the single-chip microcomputer and ADC0809, without additional power supply circuit, simplifying the system power supply design. Compared with the nixie tube, the LCD12864 does not need complex decoding and driving circuits, which further reduces the hardware circuit complexity and improves the stability of the display system.

2.3 Core Design Indicators

Combined with the practical application demands of university electronic experiment teaching and small-scale industrial on-site voltage detection, and based on the performance characteristics of the selected core devices, the core design indicators of the multi-channel digital voltmeter system are formulated, which run through the whole process of hardware design, software programming and simulation test, and serve as the core basis for verifying the effectiveness of the system design. In terms of measurement range, the system is mainly designed for the measurement of DC analog voltage signals, with the effective measurement range controlled at 0~5V, which can meet the voltage measurement requirements of most electronic experiments and small-scale industrial on-site detection scenarios. For measurement precision, the absolute error of the measured voltage value is strictly controlled within $\pm 0.02V$, which is achieved by the 8-bit conversion precision of the ADC0809 chip and the accurate data operation and processing of the single-chip microcomputer, thus ensuring the accuracy and reliability of the final measurement results. In terms of acquisition and display function, the system supports real-time cyclic acquisition and stable display of 8-channel voltage signals, and the display format is standardized as "CHX:X.XXV", which is intuitive and clear for users to distinguish and view the voltage value of each measurement channel quickly. For system response speed, the

response time from the change of the input analog voltage signal to the update of the display value on the LCD module is controlled within 1~2s, which ensures the real-time performance of the system for dynamic voltage signal measurement. In terms of over-voltage protection capability, the system is equipped with a dedicated over-voltage protection mechanism for the 0~5V measurement range; when the input voltage exceeds the 5V upper limit, the system will limit the abnormal input signal through the hardware circuit, so as to avoid the damage of core devices such as ADC0809 and single-chip microcomputer caused by over-

3. HARDWARE AND SOFTWARE IMPLEMENTATION

3.1 Hardware Circuit Implementation

This part elaborates on the specific implementation scheme of the multi-channel digital voltmeter system from two aspects of hardware circuit design and software program development, and clarifies the key connection mode of each hardware module, the core programming logic and the realization method of functional modules, so as to ensure the stable operation of the whole system and the realization of design indicators.

3.1.1 Connection of A/D Conversion Module and Voltage Acquisition Module

The A/D conversion module adopts ADC0809 chip, whose 8 analog input channels IN0~IN7 are respectively connected to the middle taps of 8 10kΩ sliding rheostats constituting the voltage acquisition module, so as to collect the adjustable analog voltage signal of 0~5V, as shown in Figure 1. The reference voltage positive terminal VREF (+) of the chip is connected to the 5V power supply, and the reference voltage negative terminal VREF (-) is grounded, which defines the effective input range of the analog voltage signal of the chip and provides a stable voltage reference for the A/D conversion process, ensuring the accuracy of the conversion result.

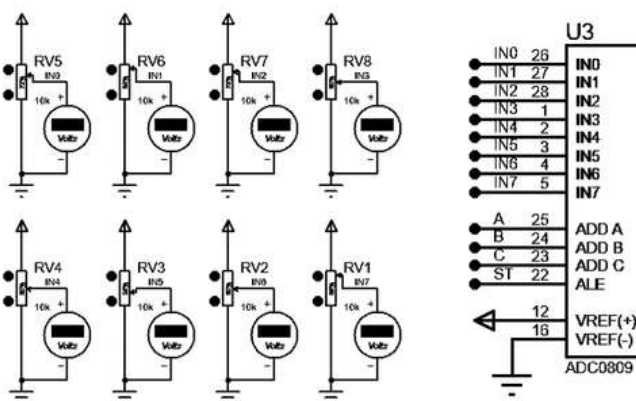

Figure 1 A/D Conversion Circuit Diagram

3.1.2 Connection of A/D Conversion Module and Main Control Module

The ADC0809 chip is connected with the AT89C51 single-chip microcomputer through parallel ports and dedicated control pins,

limit voltage and ensure the safe and stable operation of the whole system. In terms of system stability, the system can maintain continuous and stable long-time operation, and the measured data has no obvious drift during the operation process; after multiple restarts, the system can complete the initialization process normally, and all functional modules can run stably without abnormal conditions, which meets the practical application requirements of long-time continuous voltage monitoring in teaching and industrial scenarios.

realizing the transmission of conversion data and the control of conversion timing. The 8-bit data output pins D0~D7 of the chip are connected to the P3.0~P3.7 pins of the single-chip microcomputer in one-to-one correspondence, which is used to transmit the digital signal converted by the chip to the main control module. The output enable pin OE is connected to P1.0, the conversion end signal pin EOC is connected to P1.1, the start conversion signal pin START and the address latch enable pin ALE are commonly connected to P1.2, and the clock signal pin CLK is connected to P1.3. The channel selection address lines ADDA, ADDB and ADDC are respectively connected to P1.4, P1.5 and P1.6, and the single-chip microcomputer controls the on-off of each pin to realize the selection of the analog input channel, the start of conversion, the judgment of conversion state and the reading of conversion data, without additional logic control chip, simplifying the circuit structure.

3.1.3 Connection of Display Module and Main Control Module

The LCD12864 dot matrix display module is connected with the AT89C51 single-chip microcomputer through an 8-bit parallel communication mode, and the data transmission and display control of the module are realized by using the P0 port and part of the P2 port of the single-chip microcomputer. The 8-bit data bus DB0~DB7 of the module are connected to the P0.0~P0.7 pins of the single-chip microcomputer, which is the main channel for transmitting display instructions and voltage data. The control pins of the module are connected to the P2 port of the single-chip microcomputer, among which the enable signal E is connected to P2.0, the read-write selection signal RW is connected to P2.1, the data/instruction selection signal DI is connected to P2.2, and the chip selection signals CS1 and CS2 are respectively connected to P2.4 and P2.3. The single-chip microcomputer controls the level change of each control pin to realize the writing of instructions and data of the display module, and realize the flexible control of the left and right half screens and the whole screen display of the LCD12864, meeting the display demand of 8-channel voltage data, as shown in Figure 2.

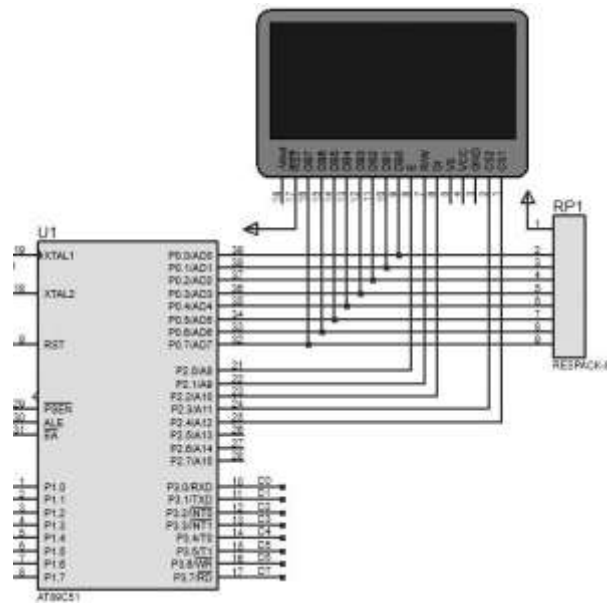

Figure 2 LCD Display Circuit Diagram

3.1.4 Design of the Minimum System of Single-chip Microcomputer

The minimum system of AT89C51 single-chip microcomputer is the foundation of the whole hardware circuit, which is composed of clock oscillation circuit, reset circuit and power supply circuit, ensuring the basic operation of the single-chip microcomputer, as shown in Figure 3. The clock oscillation circuit adopts an internal clock mode, which is composed of a 12MHz crystal oscillator and two 22pF capacitors, connected to the XTAL1 and XTAL2 pins of the single-chip microcomputer, providing a stable clock signal for the operation of the single-chip microcomputer and each peripheral module. The reset circuit is connected to the RST pin of the single-chip microcomputer, and the high level of more than two machine cycles is generated by the combination of resistance and capacitance to realize the reset of the single-chip microcomputer, ensuring that the system can return to the initial state after power-on or abnormal operation. The power supply pin VCC of the single-chip microcomputer is connected to 5V power supply, and GND is grounded, providing stable power support for the work of the single-chip microcomputer.

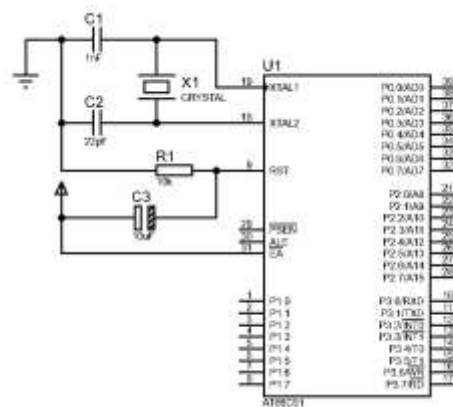

Figure 3 Circuit diagram of the minimum system of a microcontroller

3.2 Software Program Development

The software program of the system is compiled in C language based on the Keil C51 development environment, and the generated HEX file is burned into the AT89C51 single-chip microcomputer to realize the control of each hardware module. The program adopts a modular design idea, which is divided into main program, A/D conversion subprogram, LCD display subprogram and delay subprogram according to the functional requirements. Each subprogram has an independent functional logic, which is convenient for program debugging and subsequent function expansion. [5]The core programming logic and functional realization of the program are as follows:

3.2.1 Overall Logic of the Main Program

The main program is the core of the whole software system, which is responsible for the initialization of the system and the cyclic execution of each functional subprogram, realizing the continuous acquisition and display of 8-channel voltage signals. After the system is powered on, the main program first executes

the delay operation to ensure that the single-chip microcomputer and each peripheral module complete the power-on reset stably. Then it calls the LCD initialization subprogram to set the 8-bit parallel communication mode of the LCD12864 module, adjust the display contrast, turn on the display function and clear the screen, ensuring that the display module is in a ready state. After that, the timer 0 of the single-chip microcomputer is initialized, set to 16-bit automatic reload mode, and the initial value is assigned to make the timer generate an interrupt every 2ms. The clock signal of about 250kHz required for the work of the

3.2.2 Overall Logic of the Main Program

The main program is the core of the whole software system, which is responsible for the initialization of the system and the cyclic execution of each functional subprogram[6], realizing the continuous acquisition and display of 8-channel voltage signals. After the system is powered on, the main program first executes the delay operation to ensure that the single-chip microcomputer and each peripheral module complete the power-on reset stably. Then it calls the LCD initialization subprogram to set the 8-bit parallel communication mode of the LCD12864 module, adjust the display contrast, turn on the display function and clear the screen, ensuring that the display module is in a ready state. After that, the timer 0 of the single-chip microcomputer is initialized, set to 16-bit automatic reload mode, and the initial value is assigned to make the timer generate an interrupt every 2ms. The clock signal of about 250kHz required for the work of the ADC0809 chip is generated by flipping the level of the clock pin in the interrupt service function. After the initialization is completed, the main program enters an infinite loop, successively calling the A/D conversion subprogram to collect the 8-channel voltage data, performing data calculation and format conversion on the collected AD values, and then calling the LCD display subprogram to display the processed voltage values on the LCD12864 module in a standardized format, realizing the real-time and cyclic monitoring of the voltage signals.

3.2.3 A/D Conversion Subprogram

The A/D conversion subprogram is responsible for the control of the ADC0809 chip's working timing and the acquisition of conversion data, realizing the accurate conversion of analog voltage signals to digital signals. The subprogram first sets the address pins of the ADC0809 chip according to the channel number to be collected, completing the selection of the analog input channel. Then it pulls down the start conversion signal pin and delays for a certain time, then pulls it up to trigger the A/D conversion, and immediately pulls it down again to make the chip enter the conversion state. After that, the subprogram enters a waiting state and cyclically detects the level of the conversion end

4. TEST AND RESULT ANALYSIS

The designed multi-channel digital voltmeter system was simulated and verified based on the Proteus 8 Professional platform, with the program HEX file compiled by Keil C51 burned into the AT89C51 single-chip microcomputer model to realize the joint operation of hardware and software. The

ADC0809 chip is generated by flipping the level of the clock pin in the interrupt service function. After the initialization is completed, the main program enters an infinite loop, successively calling the A/D conversion subprogram to collect the 8-channel voltage data, performing data calculation and format conversion on the collected AD values, and then calling the LCD display subprogram to display the processed voltage values on the LCD12864 module in a standardized format, realizing the real-time and cyclic monitoring of the voltage signals.

signal pin EOC. When the EOC pin jumps from low level to high level, it indicates that the A/D conversion is completed. At this time, the subprogram pulls up the output enable pin OE, reads the 8-bit AD value from the P3 port of the single-chip microcomputer, and then pulls down the OE pin to close the data output of the chip. The collected AD value is transmitted to the main program for subsequent data processing, and the subprogram completes the acquisition of the voltage data of a single channel. By calling the subprogram 8 times in the main program and setting different channel numbers each time, the cyclic acquisition of 8-channel voltage data is realized.

3.2.4 LCD Display Subprogram

The LCD display subprogram is responsible for the driving control of the LCD12864 module and the formatted display of voltage data, realizing the clear and intuitive display of 8-channel voltage values. The subprogram is based on the KS0108 driver chip of the LCD12864 module, and strictly follows the timing protocol of the module to complete the writing of instructions and data through the control of the DI, RW and E pins. The subprogram predefines the 8×16 dot matrix data of numbers 0-9, decimal point and unit "V" in the header file, and stores them in the CODE area of the single-chip microcomputer for quick call during display. The subprogram sets the display coordinate through the coordinate positioning function, and automatically switches the chip selection signals CS1 and CS2 according to the horizontal coordinate to realize the display control of the left and right half screens. For the voltage data processed by the main program, the subprogram separates the integer part and the decimal part through integer division and modulo operation, converts the digital value into the corresponding dot matrix data, and writes it into the display memory of the LCD module in combination with the predefined decimal point and unit "V" dot matrix data, realizing the standardized display of the voltage value in the format of "CHX:X.XXV". The 8-channel voltage data are displayed in 4 rows on the LCD12864 module, 2 channels per row, which makes the display interface clear and easy to view.

experimental results of the system's core performance are demonstrated and analyzed as follows.

The system realizes stable acquisition and formatted display of 8-channel 0~5V DC analog voltage signals on the LCD12864 module in the form of "CHX:X.XXV", as shown in Figure 4. In terms of measurement accuracy, the absolute error between the voltage value displayed by each channel and the actual input

value is controlled within $\pm 0.02V$, meeting the preset precision requirements. For response performance, the system completes A/D conversion, data processing and display update within 1~2s after the input voltage changes, with consistent response speed of each channel and good real-time performance.

In the continuous operation test, the LCD12864 module displays stably without flicker, data disorder or loss, and each functional module can be initialized normally and run stably after multiple system restarts, showing good operational stability. When the input voltage exceeds the 5V upper limit of the measurement range, the system's hardware circuit can effectively limit the abnormal over-voltage signal, ensuring that core devices such as ADC0809 and AT89C51 are not damaged and the whole system runs safely.

The above experimental results confirm that the designed multi-channel digital voltmeter system has reliable performance, and all core functional indicators meet the design expectations, which

verifies the rationality of the system's hardware circuit design and the validity of the software program logic.

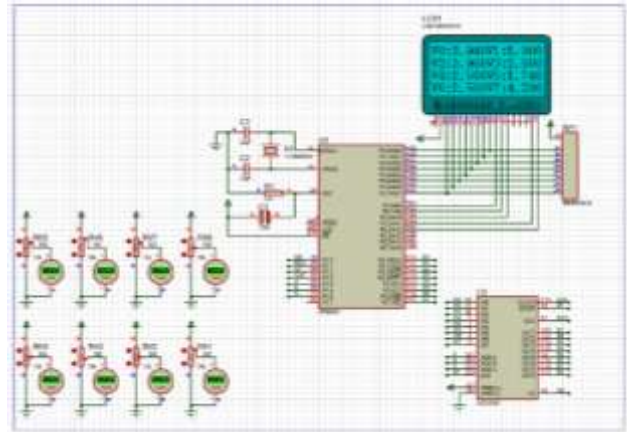

Figure 4 System Operation Effect Diagram

Mechanics and Materials,2014,2935(484-485):1126-1129.

5. CONCLUSION

This paper designs a multi-channel digital voltmeter simulation system with AT89C51 single-chip microcomputer as the core and ADC0809 as the A/D conversion chip, based on the Proteus platform. The system is modularly constructed with analog voltage acquisition, A/D conversion, core control and display modules, featuring simple hardware connection and clear software logic.

Simulation results show that the system can realize real-time cyclic acquisition and stable formatted display of 8-channel 0~5V DC voltage signals, with the measurement error controlled within $\pm 0.02V$. It has fast response speed, good operational stability and effective over-voltage protection performance, and all core performance indicators meet the preset design requirements.

The designed system has high practical application value and expandability, which is suitable for university electronic experiment teaching and small-scale industrial on-site voltage monitoring scenarios, and also provides a feasible low-cost design reference for the development of simple digital voltage measurement equipment.

6. REFERENCES

- [1] Lu G Q. Design of Digital Voltmeter Based on Single Chip Microcomputer[J]. Science and Technology Innovation, 2017(36):35-36.
- [2] Sha Z Y. Principle and Application of New Digital Voltmeter[M]. Beijing: China Machine Press, 2006: 5-6.
- [3] Sha Z Y. Digital Measurement Technology and Application[M]. Beijing: China Machine Press, 2004: 205-206.
- [4] Tan H Q. Principle and Application of Microcomputer (3rd Edition)[M]. Beijing: Tsinghua University Press, 2008.
- [5] Tan H Q. C Language Programming (2nd Edition) [M]. Beijing: Tsinghua University Press, 2010.
- [6] Wang W .Design of Digital Control DC Voltage Source Based on AT89C52 MCU[J].Applied